



TESLA



Universal Wall Connector Manual

48A Single Phase

	Torque Specifications.....	41	
Important Safety Information.....	2	Warranty Information.....	42
Product Overview.....	5	Limits of Liability.....	43
Product Specifications.....	5	Dispute Resolution.....	44
Circuit Breaker Rating / Maximum Output.....	6		
Using Wall Connector.....	8		
Features.....	10		
Connectivity.....	10		
Hosted Access Point.....	10		
Local Network.....	11		
Ground Fault Circuit Interruption.....	12		
Ground Assurance.....	12		
Power Outages.....	13		
Firmware Updates.....	13		
Wall Connector External Components.....	14		
Wall Connector Internal Components.....	15		
Installation.....	16		
In the Box.....	16		
Tools.....	17		
Installation Considerations.....	18		
Step 1: Prepare Wirebox for Conduit Fittings and Bushings.....	21		
Step 2: Prepare Mounting Surface.....	22		
Step 3: Prepare Wirebox and Mount to Wall.....	23		
Step 4: Route Wiring Through Wirebox.....	24		
Step 5: Strip and Land Wiring.....	25		
Step 6: Attach Wall Connector to Wirebox.....	26		
Step 7: Energize Wall Connector.....	27		
Commissioning Procedure.....	28		
.....	29		
Power Sharing.....	30		
Power Sharing Overview.....	30		
Breaker and Branch Circuit Setup.....	31		
Considerations for Power Sharing.....	32		
Calculating Power Sharing Requirements for Existing Systems.....	32		
Setting Up Power Sharing.....	32		
How to View Existing Power Sharing Networks.....	37		
Registering the Wall Connector in the Tesla App - Vehicle Owners.....	38		
Wall Connector LEDs.....	39		
Light Codes.....	39		
Fault Codes.....	40		



IMPORTANT SAFETY INFORMATION

Read all instructions before using this product. Save these instructions.

This manual contains important instructions for the NACS connector that shall be followed during installation, operation, and maintenance. Please review all warnings and cautions before installing and using the Wall Connector.

 **WARNING:** When using electric products, basic precautions should always be followed, including the following.

INSTRUCTIONS RELATING TO RISK OF FIRE OR ELECTRIC SHOCK

 **WARNING:** Do not install or use the Wall Connector near flammable, explosive, harsh, or combustible materials, chemicals, or vapors.

 **WARNING:** Turn off power at the circuit breaker before installing or cleaning the Wall Connector.

WARNINGS

 **WARNING:** This product can expose you to one or more chemicals that are known to the state of California to cause cancer.

 **WARNING:** This device should be supervised when used around children.

 **WARNING:** The Wall Connector must be grounded through a permanent wiring system or an equipment-grounded conductor.

 **WARNING:** Use the Wall Connector only within the specified operating parameters.

 **WARNING:** Never spray water or any other liquid directly at the wall mounted control box. Never spray any liquid onto the charge handle or submerge the charge handle in liquid. Store the charge handle in the dock to prevent unnecessary exposure to contamination or moisture.

 **WARNING:** Do not use the Wall Connector if it is defective, appears cracked, frayed, broken, or otherwise damaged, or fails to operate.

 **WARNING:** Do not use the Wall Connector if the flexible power cord or cable is frayed, broken, or otherwise damaged, or fails to operate.

 **WARNING:** Do not attempt to disassemble, repair, tamper with, or modify the Wall Connector. The Wall Connector is not user serviceable. Contact Tesla for any repairs or modification.

 **WARNING:** When transporting the Wall Connector, handle with care. Do not subject it to strong force or impact or pull, twist, tangle, drag, or step on the Wall Connector, to prevent damage to it or any components.



IMPORTANT SAFETY INFORMATION

 **WARNING:** Do not touch the Wall Connector's end terminals with fingers or sharp metallic objects, such as wire, tools, or needles.

 **WARNING:** Do not insert fingers or foreign objects into any part of the Wall Connector.





 **WARNING:** Do not forcefully fold or apply pressure to any part of the Wall Connector or damage it with sharp objects.

 **WARNING:** Use of the Wall Connector may affect or impair the operation of any medical or implantable electronic devices, such as an implantable cardiac pacemaker or an implantable cardioverter defibrillator. Check with your electronic device manufacturer concerning the effects that charging may have on such electronic devices before using the Wall Connector.







IMPORTANT SAFETY INFORMATION

CAUTIONS

-  **CAUTION:** Do not use private power generators as a power source for charging.
-  **CAUTION:** Incorrect installation and testing of the Wall Connector could potentially damage the vehicle's battery, components, and/or the Wall Connector itself. Any resulting damage is excluded from the New Vehicle Limited Warranty and the Charging Equipment Limited Warranty.
-  **CAUTION:** Do not operate the Wall Connector in temperatures outside its operating range of -22° F to 122° F (-30° C to 50° C).
-  **CAUTION:** Wall Connector should only be installed by personnel who are trained and qualified to work on electrical systems.
-  **CAUTION:** Ensure that Wall Connector is within storage temperature when moving, transporting, or storing.

Notes

-  **NOTE:** Ensure that the Wall Connector's charging cable is positioned so it will not be stepped on, driven over, tripped on, or subjected to damage or stress.
-  **NOTE:** Do not use cleaning solvents to clean any of the Wall Connector's components. The outside of the Wall Connector, the charging cable, and the connector end of the charging cable should be periodically wiped with a clean, dry cloth to remove accumulation of dirt and dust.
-  **NOTE:** : Be careful not to damage the circuit boards or components during installation.
-  **NOTE:** Use a cable sheath or similar containment to cover the supply cables. The color black is recommended.



PRODUCT OVERVIEW

Product Specifications

This manual applies to Wall Connectors identified by part number 1734412-XX-X.

Voltage and Wiring	Nominal 200-240 V AC single-phase
Current Output Range	12 - 48 amps
Terminal Blocks	12-4 AWG G (3.5 - 25 mm ²), copper
Supported Conduit Sizing	¾" (21 mm) default, 1" (27 mm) optional
Grounding Scheme	TN/TT
Frequency	50/60 Hz
Cable Length	24 in (7.3 m)
Wall Connector Dimensions	Height: 13.6 in (345 mm) Width: 6.1 in (155 mm) Depth: 5.9 in (150 mm)
Wire Box Bracket Dimensions	Height: 9.8 in (250 mm) Width: 4.7 in (120 mm) Depth: 3.5 in (90 mm)
Weight (including wirebox)	12.6 lbs (5.7 kg)
Operating Temperature	-22°F to 122°F (-30°C to 50°C)
Storage Temperature	-40°F to 185°F (-40°C to 85°C)
Enclosure Rating	Type 3R
Ventilation	Not required
Means of Disconnect	External branch circuit breaker
Wi-Fi	2.4 GHz, 802.11b/g/n
Agency Approvals	ETL/cETL

Transportation and storage: Ensure that Wall Connector is within storage temperature when moving, transporting, or storing.

This device complies with part 15 of the FCC Rules. Operation is subject to the following conditions: (1) This device may not cause harmful interference, and (2) this device must accept any interference received, including interference that may cause undesired operation.



Circuit Breaker Rating / Maximum Output

Power Output

For maximum power output, install a standard double pole 60 amp circuit breaker.

Wall Connector incorporates automatic load management, which allows the max output to be customized to an existing power supply.

If the electrical supply is unable to support the 60 amp configuration, select a lower amperage configuration.

Circuit breaker (amps)	Max output (amps)	Power output at 240 volts (kW)
60	48	11.5
50	40	9.6
40	32	7.6
30	24	5.7
20	16	3.8
15	12	2.8



NOTE: External disconnect switches are neither required nor recommended.



NOTE: Circuit breaker size is programmed during the commissioning process. See [Commissioning Procedure on page 28](#) for details.



NOTE: Some Tesla vehicles may draw less current than the max output. Actual charging rate depends on Wall Connector output and onboard charger in the vehicle.

Branch Circuit Conductors and Ground Wire

- If installing for less than maximum power, refer to local electrical code to select correct conductors and ground wire size that are suitable for the chosen circuit breaker.
- For maximum power, check temperature rating of circuit breaker used:
 - For 60°C rated circuit breaker, use minimum 4AWG, 90°C THWN-2-rated copper wire for conductors.
 - For 75°C rated circuit breaker, use minimum 6AWG, 90°C THWN-2-rated copper wire for conductors.



NOTE: Increase conductor size if necessary.

- For sites with multiple Wall Connectors, the power sharing feature can enable the safe utilization of a single branch circuit. See single line examples in [Breaker and Branch Circuit Setup on page 31](#).
- COPPER WIRE TERMINATIONS ONLY for landing in Wall Connector wirebox terminals. Conductors can be stranded or solid.
- Hardwire branch circuits to disconnects or circuit breakers. Do **NOT** install cord-and-plug type connections.
- For outdoor installations, use watertight fittings when securing feeder wires to the wirebox.



Grounding Connections

Wall Connector must have a ground path back to the main equipment earthing point on site. Without a proper ground connection, the Wall Connector will fault during a ground assurance test. Equipment-grounding conductor must be run with the circuit conductors and connected to the equipment-grounding terminal in the wirebox. Install a ground (PE) wire sized according to local electrical code.



Using Wall Connector

1. Remove the NACS connector by pressing the button on the charge handle, pressing on the charge port door, using the mobile app, using the vehicle touchscreen, or by pressing and holding the trunk button on the keyfob.



2. Press the silver button on the J1772 adapter to remove the handle from the dock.



3. Insert the charge handle into the vehicle charge port.
4. Check the vehicle controls to verify charging.
5. To remove the charge handle from the vehicle, press and hold the button on the handle to unlock the charge port.



NOTE: The vehicle must be unlocked for the charge handle to be removable.

6. Remove the charge handle from the vehicle charge port.
7. Wrap the charge cable counter-clockwise around the Wall Connector and insert the charge handle into the holster.



Features

Connectivity

Wall Connector is equipped with Wi-Fi to communicate with local site routers, vehicles, mobile devices, other Wall Connectors, and other Tesla products.

Press and hold the button on the connector for 5 seconds. The Wall Connector will then be available to connect to WiFi for 15 minutes.

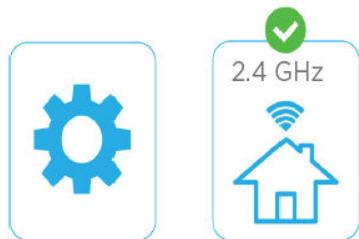
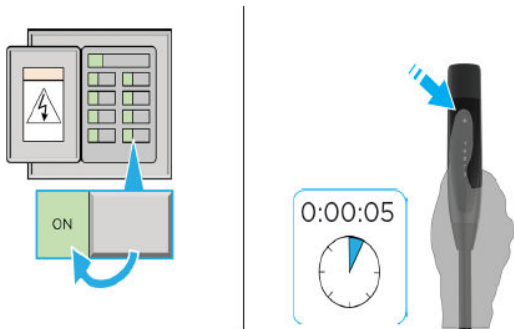

Hosted Access Point

Wall Connector hosts a WPA2 password-secured, 2.4 GHz, 802.11 Wi-Fi access point network to facilitate commissioning and connecting to other devices.



PRODUCT OVERVIEW

A unique SSID Wi-Fi network name and WPA2 password for connecting to the Wall Connector are printed on a label at the rear of the main unit, as well as on the front cover of the Quickstart Guide included in the box.

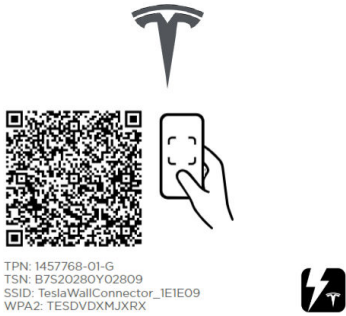

Universal Wall Connector





Quickstart Guide
Guía Rápida
Guide Rapide
クイックガイド
빠른 설치 설명서
快速入门指南

Local Network

Connecting Wall Connector to a local Wi-Fi network enables it to receive over-the-air firmware updates, remote diagnostics access, and usage data tracking capability. A Wi-Fi connection is required for sites that utilize authentication, billing, and other property management features.

Wall Connector only supports WPA2/3-secured, 2.4 GHz, 802.11 infrastructure mode networks.

 **NOTE: Networks that are not password protected are not supported. The Wall Connector will not display non-password protected networks in the options list.** Open networks without a password are not supported and will not be recognized by the Wall Connector.

 **NOTE:** WPA enterprise will be supported in a future firmware update.

 **NOTE:** Property management features will be enabled via future firmware updates.



Ground Fault Circuit Interruption

Integrated ground fault circuit interruption (GFCI) protection automatically detects a current mismatch between power delivery conductors that would indicate that current is flowing through the ground (PE) conductor.

If a ground fault occurs after 10 seconds of charging, Wall Connector will wait 15 minutes before automatically re-attempting to charge. Up to four attempts to charge will be made before user interaction is required.

If a ground fault occurs within 10 seconds of charging, Wall Connector will lock out and user interaction is required to restore charging functionality.

Recommended interaction includes pressing the button on the charging handle, or removing the charging handle from the vehicle and reinserting it. If this does not resolve the issue, look for a ground fault issue such as water ingress.

Ground Assurance

Wall Connector continuously checks for the presence of a safe ground connection and automatically recovers from faults. Ground assurance operates by injecting a small amount of current into the ground conductor in order to measure the impedance between line and ground. If high impedance is detected, the Wall Connector will lock out charging and display a fault code of two (2) red blinks. See [Fault Codes on page 40](#) for a full list of fault codes.

For ground assurance to operate on TN grids, one leg of the distribution transformer must be ground - bonded (Neutral). Ground bond should only occur at one location in a site's electrical system.

Wall Connector ground assurance may be adjusted in countries with TT or IT grid configurations and can be disabled in the commissioning procedure.

The Ground Monitor Interrupter feature monitors the Wall Connector ground connection. Select the correct option based on the installation's earthing system and earth impedance.

Depending on country, three options are available:

- **Enable:** Ground connection will be monitored and a high detected. Ground resistance will disable the Wall Connector. This is the preferred setting to provide protection, and should be selected where ground connection is expected to be strong (as in the case on TN networks and most TT networks), and where required by regulation.
- **Monitor:** Ground connection will be monitored but a high detected ground resistance will not disable the Wall Connector. This should be selected if the ground monitoring check yields false positives and ground impedance cannot be improved (as is the case in some TT networks).
- **Disabled:** Ground connection will not be monitored. This should be selected where the ground connection is not made (as is the case for IT networks), or where the current induced by this check would be problematic (as is the case on some TT networks with sensitive residual-current devices).



NOTE: Ground Monitoring is always enabled for installations in North America.

Temporary problems such as ground faults or utility power surges are resolved automatically.



Power Outages

If there is a power outage while Wall Connector is charging a vehicle, charging will automatically resume within 1 to 3 minutes after power restoration. The Wall Connector will display a solid blue light on the faceplate to indicate that it is communicating with the vehicle and waiting to resume charging. Alternatively, pressing the button on the charge handle after power restoration will cause Wall Connector to resume charging immediately.

 **NOTE:** Wall Connectors in a power sharing group maintain their power sharing settings after a power loss event.

Firmware Updates

Firmware updates will be automatically applied to the Wall Connector to improve the user experience and introduce new features. Connect Wall Connector to Wi-Fi for access to the most recent firmware update. See [Commissioning Procedure on page 28](#).



Wall Connector External Components

"Wall Connector" refers to the product as a whole.

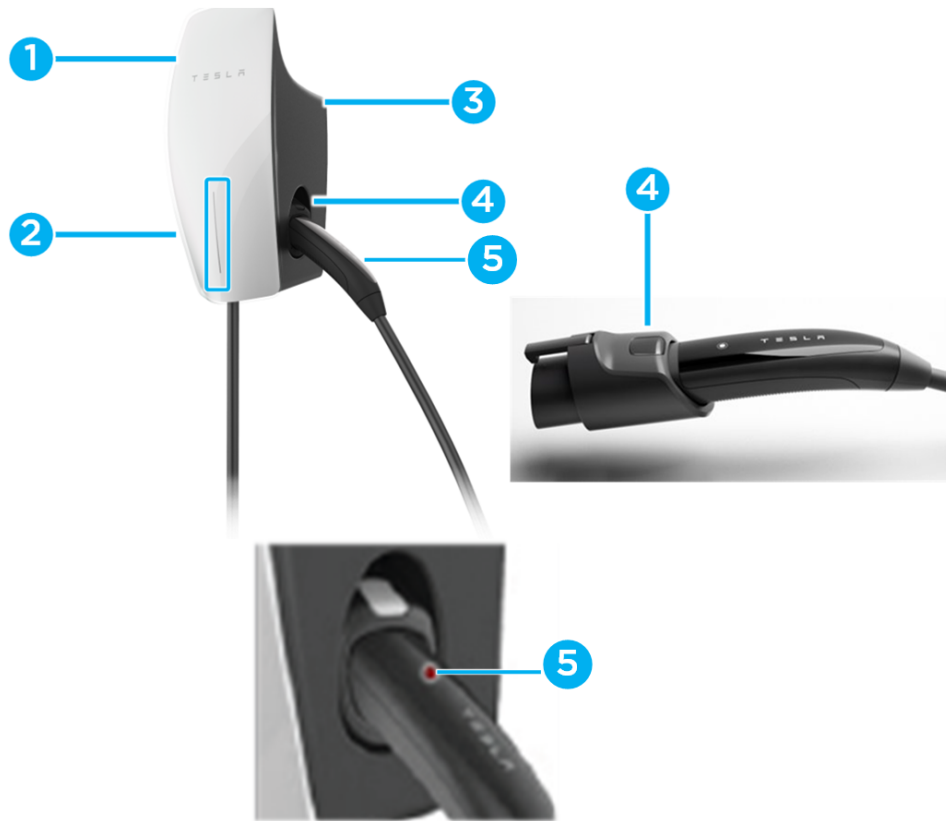

1. Faceplate
2. Light bar (vertical)
3. Main unit
4. J1772 charge port adapter
5. NACS handle



Wall Connector Internal Components

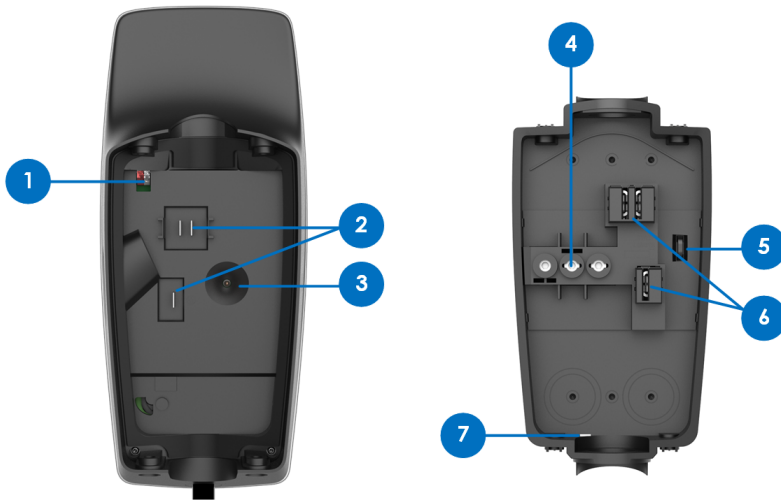









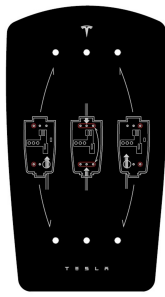

1. RS-485 port
2. Contact blades
3. Temperature sensor
4. Conductor terminals
5. Zip tie anchor
6. Sliding contacts
7. Wirebox drainage opening (enables Type 3R protection)



INSTALLATION

In the Box

 <p>Main Unit</p>	 <p>Wirebox</p>	 <p>Wirebox Mounting Template</p>	 <p>Hex Bit (4 mm)</p>	
 <p>Zip tie (x1)</p>	 <p>Main Unit-to-Wirebox Fastener (x4)</p>	 <p>Wirebox-to-Wall Fastener (x2)</p>	 <p>Quickstart Guide (contains sticker with SSID network name and unique password)</p>	 <p>Sticker for breaker</p>

 **NOTE:** The hex bit, zip tie, and fasteners are located in a plastic bag inside the wirebox, which comes attached to the main unit of the Wall Connector.

 **NOTE:** Wall plugs are not included. If installing in concrete or other like materials, use 6 mm wall plugs.













Tools

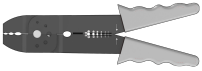

Required Tools



NOTE: Drill bit sizes assume wood mounting surfaces. If installing on concrete or other masonry, consult with an electrician for optimal pilot hole sizes.

 <p>Torque Driver (50 lbf . in, 5.6 Nm)</p>	 <p>Multimeter</p>	 <p>Stud Finder</p>	 <p>Tape Measure</p>
 <p>Wire Stripper</p>	 <p>Drill Bit, 5 mm (3/16 in)</p>	 <p>Drill Bit, 2.5 mm (3/32 in)</p>	 <p>Bit Driver</p>
 <p>Level</p>	 <p>Smartphone (with Wi-Fi)</p>	 <p>Power Drill</p>	

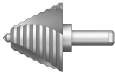
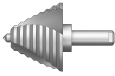
Optional Tools

 <p>Step Bit, 29 mm (1-1/8 in)</p>	 <p>Step Bit, 35 mm (1-3/8 in)</p>	 <p>Computer (with Wi-Fi)</p>
---	---	--



Installation Considerations

Wall Connector may be installed on any flat, vertical surface capable of supporting its weight (e.g. wall, pedestal, etc.). Wall Connector weighs ~10 lb (4.5 kg).

Choosing Location

Install Wall Connector in a location that allows the charge cable to reach the vehicle charge port without putting strain on the cable. Recommended installation area for Wall Connectors with 7.3 m (24 ft) cable:

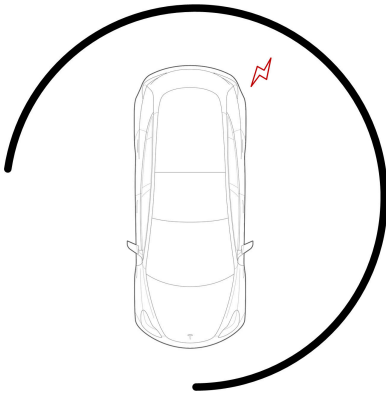

Install Wall Connector in a location with ample clearance on all sides to allow the charge cable to loop around the unit and the charge handle to comfortably land in the side dock.



NOTE: If constrained by space, a cable organizer can be installed near the Wall Connector (sold separately).

Choosing Height





INSTALLATION

- Maximum height (indoor and outdoor): 60 in (1.52 m)
- Recommended height: ~45 in (~1.15 m)
- Minimum outdoor height: 24 in (0.6 m)
- Minimum indoor height: 18 in (0.45 m)

Maximizing Wi-Fi Signal Reception

Wall Connectors should be connected to a local Wi-Fi network for optimal functionality. For maximum signal reception, avoid installing Wall Connector on opposite sides of concrete, masonry, metal studs, and other physical obstructions that could impede Wi-Fi signal reception.

 **NOTE:** If a mobile device is able to connect to local Wi-Fi at a given location, it is a good indication that Wall Connector will also be able to connect.



Wire Entry Options

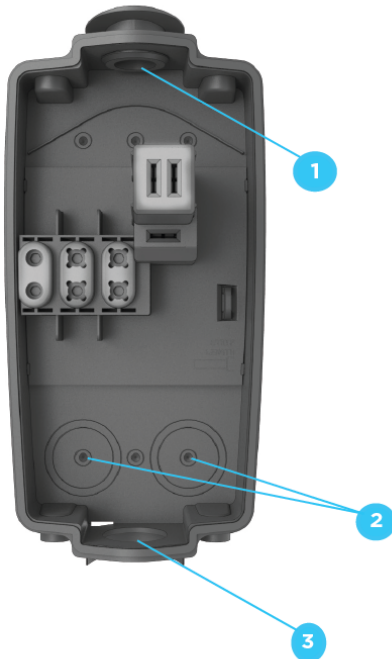

Wall Connector's wirebox has multiple wire entry options. Choose one entry path and follow installation instructions based on chosen entry path.

1. Top entry location



INSTALLATION

2. Rear entry locations (left or right)
3. Bottom entry location

For additional installation considerations on sites that will have multiple Wall Connectors, see [Considerations for Power Sharing on page 32](#).



Step 1: Prepare Wirebox for Conduit Fittings and Bushings

The default conduit size is 3/4 in (21 mm). 1 in (27 mm) conduit is acceptable if needed.

Based on fittings and conduit size, prepare the wirebox.

- For top or bottom entry: Manually remove the conduit plug.
- For rear entry: Drill with 1-1/8 in (29 mm) step bit to prepare wirebox for fittings.

Table 1. For 3/4 in (21 mm) Conduit

Top Entry	Bottom Entry	Rear Left Entry	Rear Right Entry
		 1-1/8 in (29 mm)	 1-1/8 in (29 mm)

Table 2. For 1 in (27 mm) Conduit

Top Entry	Bottom Entry	Rear Left Entry	Rear Right Entry
Do not expand.	 1-3/8 in (35 mm)	 1-3/8 in (35 mm)	 1-3/8 in (35 mm)

 **NOTE:** For 1 in (27 mm) rear and bottom entry options, drill with 1-3/8 in (35 mm) step bit to prepare wirebox for fittings.



Step 2: Prepare Mounting Surface

1. If applicable, use a stud finder to locate a wooden support stud. Plywood, or other flat wall surfaces capable of supporting the weight of the Wall Connector, may also be used.



2. Based on the chosen wire entry path, position the included cardboard mounting template onto the installation surface and use a 5/32 in (4 mm) bit to drill two pilot holes (one from the top row and one from the bottom row).



NOTE: When installing for rear left or rear right wire entry, select the two mounting holes that are on the opposite side of the wire entry point.



NOTE: Use a level tool with the cardboard mounting template to ensure a level installation as desired.

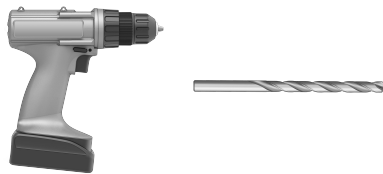

Drill bit, 5/32 in (4 mm)

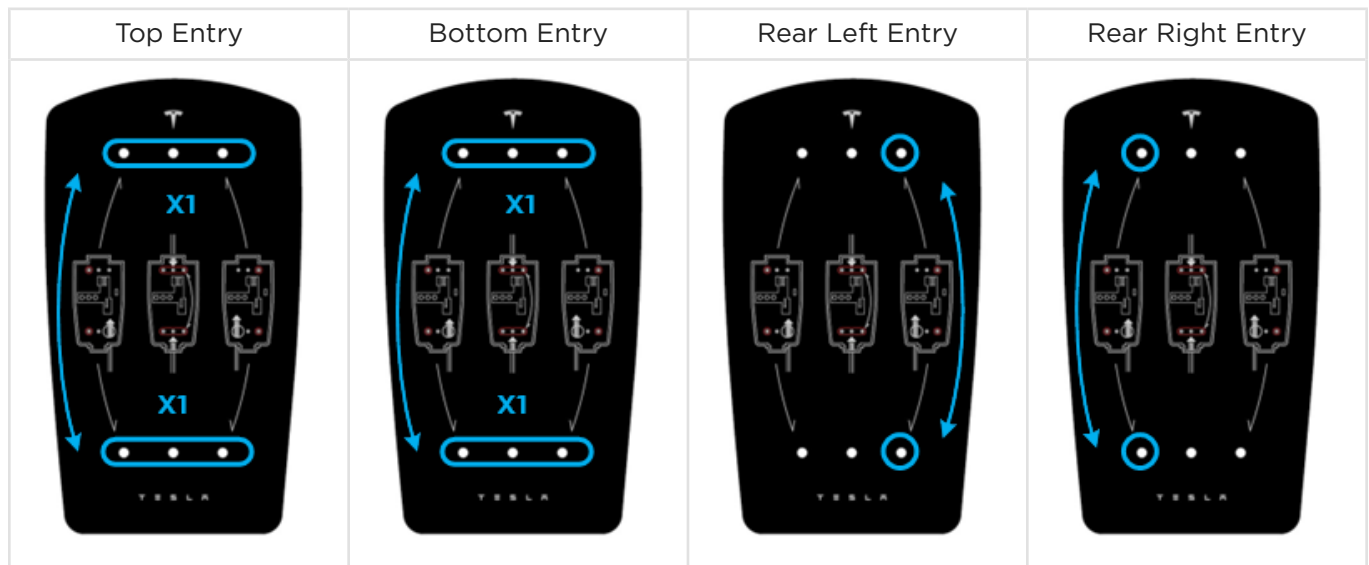



Step 3: Prepare Wirebox and Mount to Wall

1. Use a 1/4 in (6.5 mm) bit to drill two pilot holes into the wirebox that match the locations chosen on the cardboard mounting template.

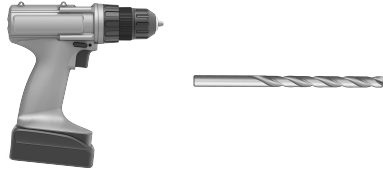

Drill bit, 1/4 in (6.5 mm)

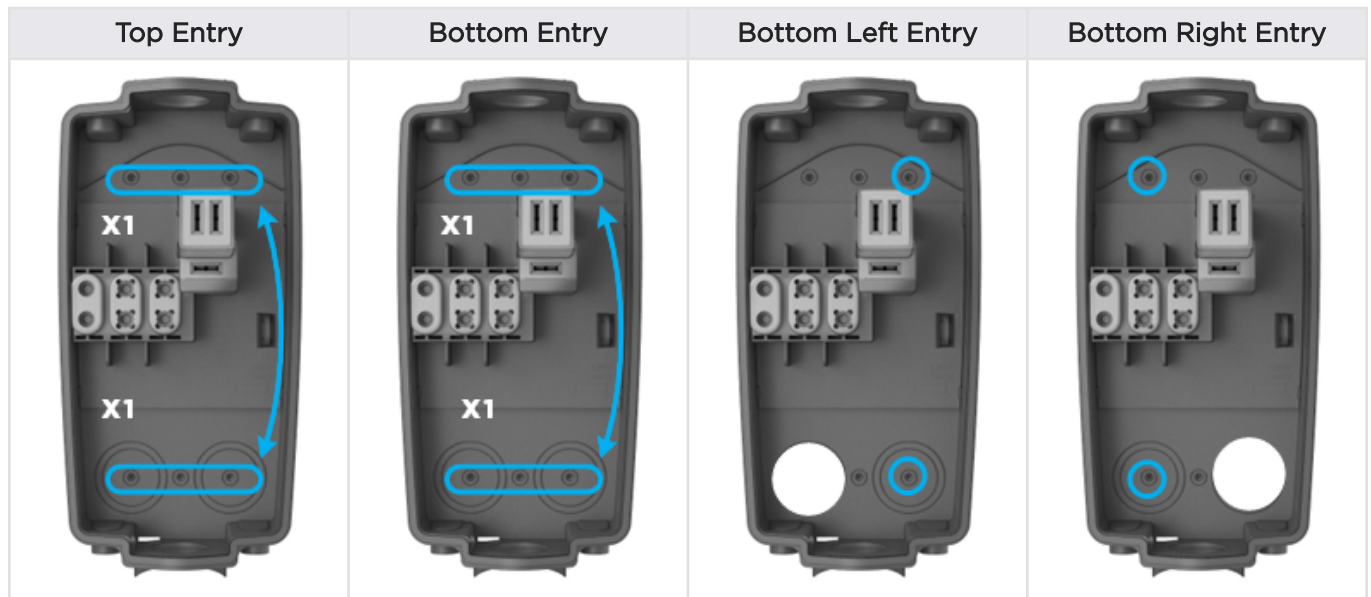

2. Attach the wirebox to the mounting location using the included 4 mm hex bit and the two included wood fastener screws.

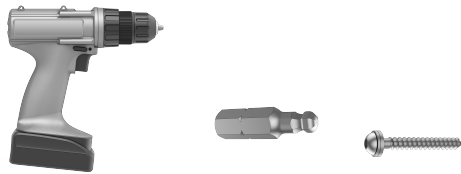

NOTE: Type 3R rating is only possible when washers have sealing gaskets. If mounting to alternate surface (such as a prefabricated pedestal), use alternate fasteners with sealing washers.



NOTE: The wood fastener screws are designed to support the weight of the entire Wall Connector, cable, and charging handle.



Step 4: Route Wiring Through Wirebox

1. Route wiring into selected entry point and through the service loop channel on the right side of the wirebox.

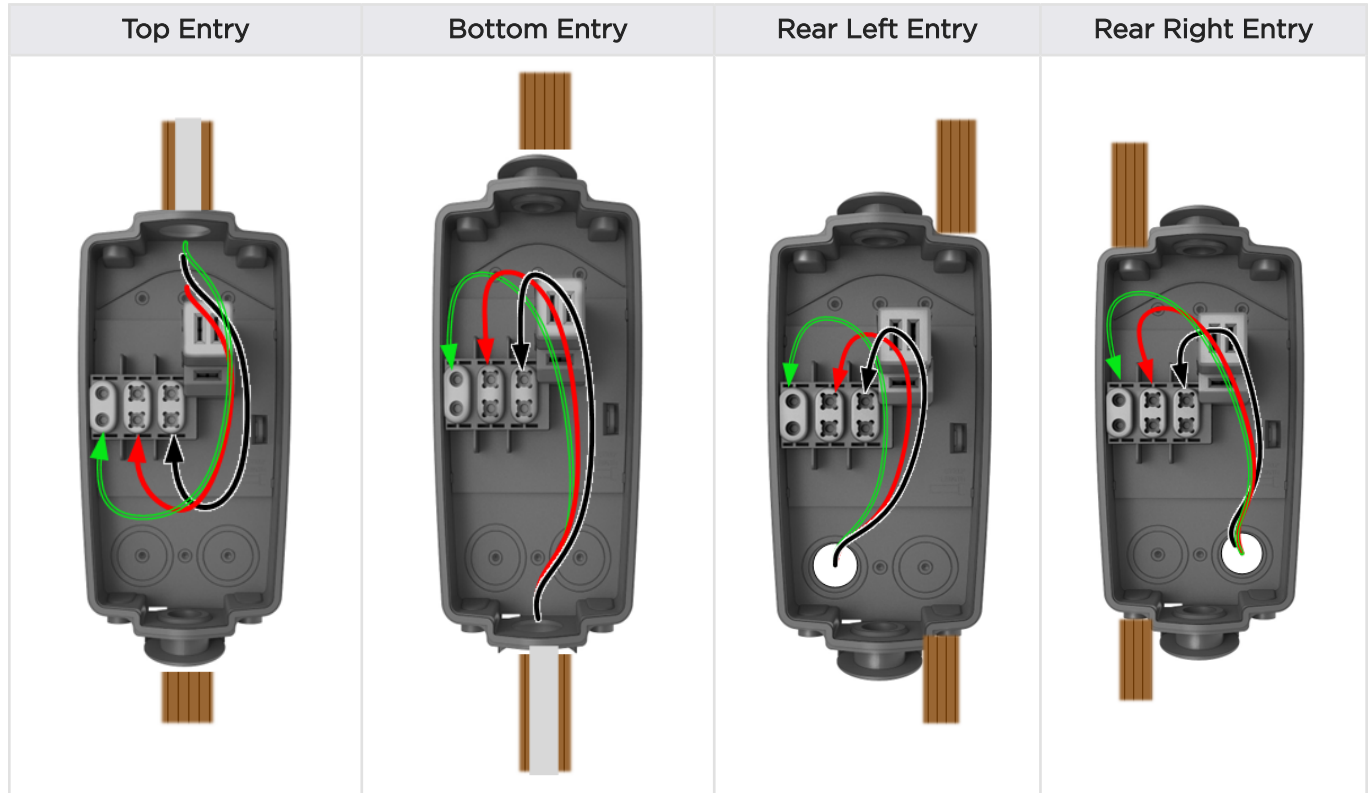

2. Use appropriate cable glands, bushings, or fittings to secure the wiring in place and protect from water and debris intrusion.



CAUTION: Ensure that bushings are in place to avoid damage to conductors and ground wire when pulled into wirebox.



CAUTION: Use copper conductors only.



NOTE: Compression-style fittings are recommended to prevent interference.



NOTE: For top or bottom wire entry, if installing fittings with a set screw, ensure that the screw is positioned to avoid interference with Wall Connector cables.



Step 5: Strip and Land Wiring

1. Strip insulation from wires $\sim 1/2$ in (~ 13 mm), route through service channel, and land each wire in its correct terminal block.



NOTE: Terminals are bi-directional.

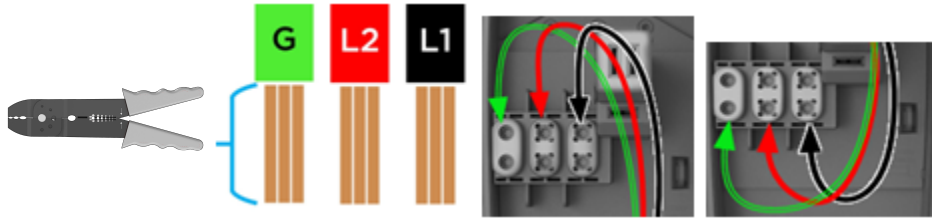

2. Secure the wiring in the service channel using the included zip tie.



3. Use a torque driver and the included 4 mm hex bit to torque the terminal screws to 50 lbf . in (5.6 Nm).

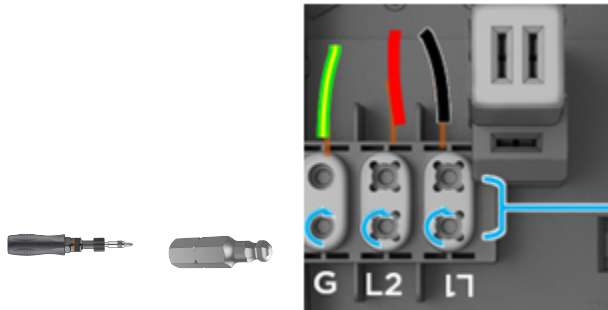

NOTE: When installing Wall Connector in a split phase electrical system, use Line-to-Line instead of Line-to-Neutral.



Step 6: Attach Wall Connector to Wirebox

1. Attach the main unit to the wirebox by pushing it inward.



NOTE: Ensure that the wire is not bent when mounting the main unit to the wirebox. The wire should not exceed 305 mm.

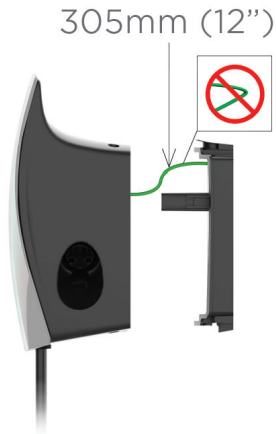

2. Secure the main unit to the wirebox with the four included fasteners and the included 4 mm hex bit using a bit driver, applying pressure to the faceplate during the process to compress the internal seal. Firmly hand-tighten the four fasteners until they are secure.



NOTE: Do not use a power drill for this step.

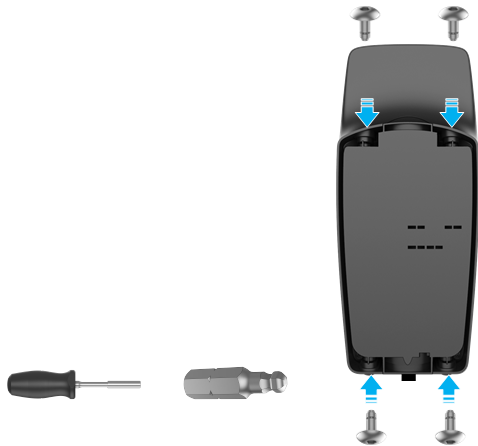



Step 7: Energize Wall Connector

1. Energize the Wall Connector by turning on the upstream circuit breaker.



NOTE: To energizing a leader/follower unit turn on the upstream circuit breaker, though multiple units will be fed by one breaker and multiple will turn on when the breaker is flipped.

There's no difference in energizing a leader/follower unit except that multiple units will be fed by 1 breaker, so multiple will turn on when the breaker is flipped.

Gen 3 Wall Connector

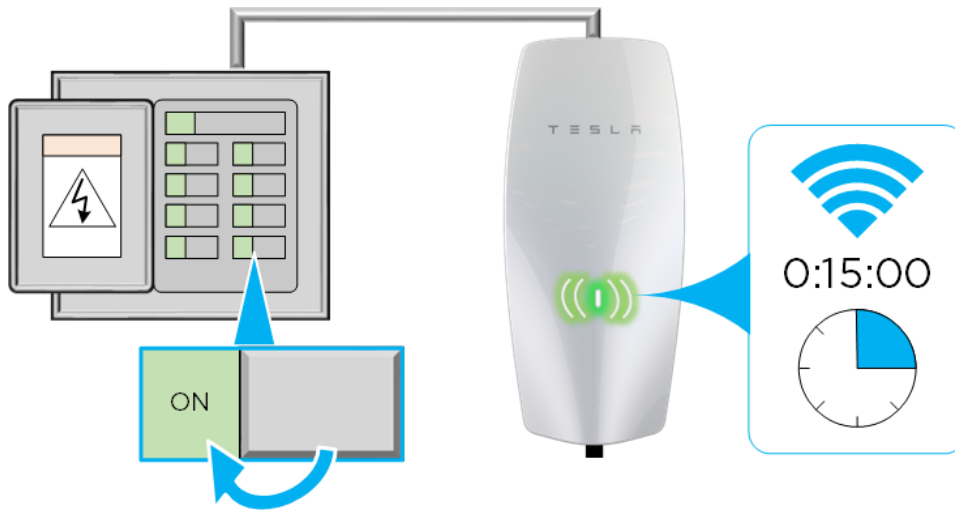

The Wall Connector's LEDs will turn on. See [Wall Connector LEDs on page 39](#).

2. Proceed with commissioning.



COMMISSIONING PROCEDURE

The commissioning process for Wall Connector enables easy configuration of circuit breaker size, Wi-Fi connectivity, and power sharing options.

1. Turn on Wall Connector's corresponding branch breaker to energize the unit.
During startup, Wall Connector will display green LEDs for 10 seconds to indicate the maximum circuit breaker it is configured for.
2. Use a Wi-Fi-enabled device such as a smart phone to connect to the SSID Wi-Fi signal broadcasted by the Wall Connector. Joining the Wall Connector network can be done by scanning the sticker QR code on the Quickstart Guide cover page, or by manually selecting the network and typing in the WPA2 password (found on the sticker on the Quickstart Guide cover page).

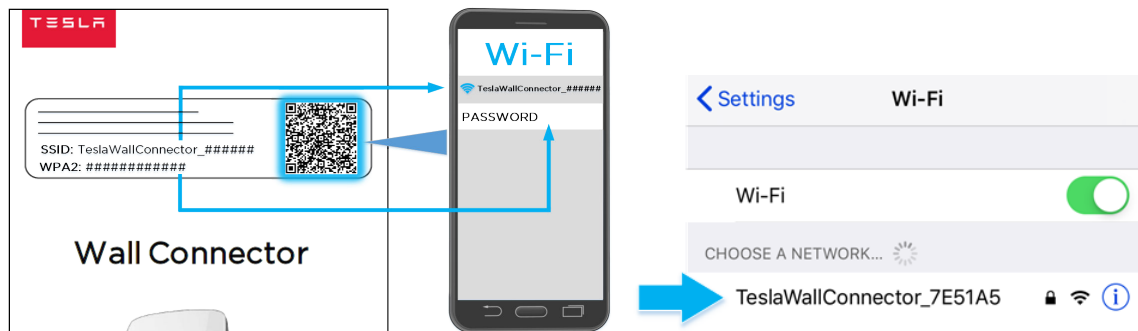

 **NOTE:** The Wi-Fi network will broadcast for 15 minutes. To have the Wall Connector broadcast the SSID again, hold the button on the charging handle for 5 seconds or turn the circuit breaker off, then on again.

 **NOTE:** If you are unable to connect to the Wall Connector SSID, turn off the cellular data function on your mobile device and try again.

3. Scan the QR code below with the device that is connected to the Wall Connector to access the web browser commissioning interface. Alternatively, manually type the URL address (<http://192.168.92.1>) into the web browser.

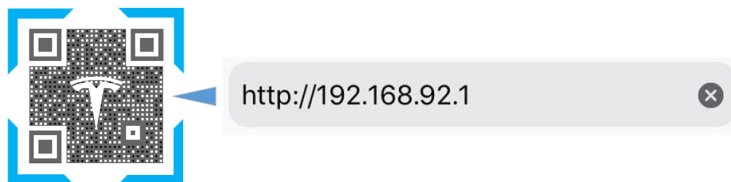

4. Follow the onscreen commissioning steps on the web browser to assign Wall Connector to its own circuit breaker and connect it to the local site Wi-Fi network.

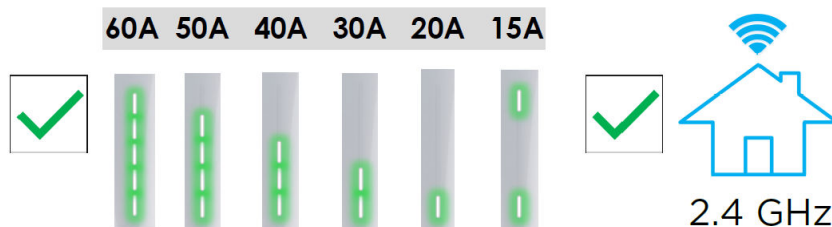



COMMISSIONING PROCEDURE



NOTE: To have the Wall Connector broadcast the SSID again, hold the button on the charge handle for 5 seconds or turn the circuit breaker off, then on again.

Scan the QR code below with the device that is connected to the Wall Connector to access the commissioning interface. Alternatively, manually type the URL address (<https://www.tesla.com/dl/reg?d=wc>) into the web browser.



Tesla Certified Installer

1. Scan the QR code on the Quick Start Guide or breaker label with phone camera app (no internet).
 - a. This will take the installer directly into the Setup App workflow for commissioning jobs.
 - i. If pros installed - Open with credentials.
 - ii. If not installed - Installer will be prompted to install Tesla Pros and will need to scan QR code again (connectivity will be required).
 - iii. Installer will also need an account to track each install.
2. Scan with Tesla Pros App.
 - a. Connect to the Wall Connector with credentials and start CX flow.
3. If the QR code fails, manually type the URL address above.

The Quick Start Guide will also have the Tesla Pros QR Code.





POWER SHARING

Power Sharing Overview

The firmware-based power sharing feature enables up to 6 Wall Connectors installed at the same site to intelligently share the site's total available power via unit-to-unit Wi-Fi. This minimizes the need for many residential and commercial applications to have specific electrical upgrades for concurrent multi-vehicle charging.

During the commissioning process,

- Wall Connectors are allocated to individual branch circuits (each up to 60 amps)
- Total power is allocated to the group of linked Wall Connectors

 **NOTE:** For instructions to commission Wall Connectors in a power sharing network, see [Gen 3 Wall Connector Power Sharing](#).

Total current output of Wall Connectors that share power will never exceed the site's total allocated power.

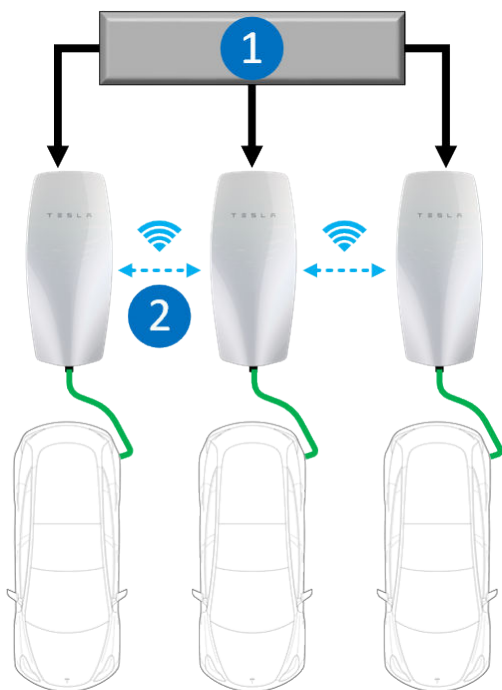

1. AC feed (service panel)
2. Power sharing via Wi-Fi communication



Breaker and Branch Circuit Setup

Power sharing circuits may be installed in an electrical panel that supports other loads. If space is limited or the main power supply is far from the Wall Connectors, installing a dedicated load center may be prudent.

See below for examples of Wall Connector power sharing diagrams (one with sub-panel and one without). Each individual Wall Connector in below examples is capable of providing 48 amps when it is the only one in use. As more Wall Connectors begin plugging into vehicles, the system will automatically distribute power based on the total power allocated to the site.

Power Sharing Setup with Sub-Panel

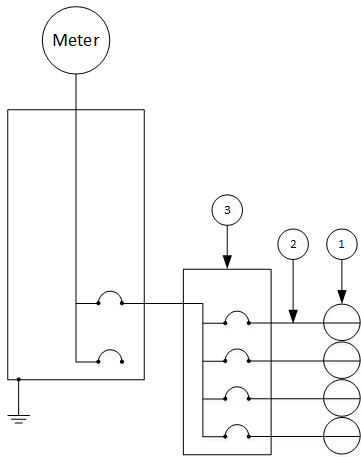

1. Wall Connector
2. 60 A branch circuit
3. 100 A sub-panel / feeder breaker

Power Sharing Setup Without Sub-Panel

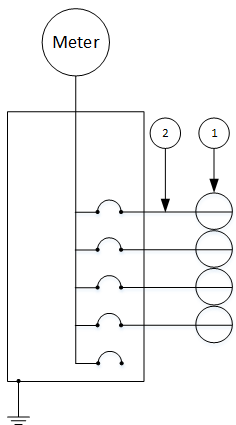

1. Wall Connector
2. 60 A branch circuit



Considerations for Power Sharing

Wall Connector power sharing is achieved wirelessly.

For optimal performance, Wall Connectors within a power sharing network should be installed within view of each other whenever possible.

 **NOTE:** Line of sight is recommended but not required. Wireless communication is capable of reaching around concrete corners but network range may degrade as a result.

Avoid placing Wall Connectors on opposite sides of concrete, masonry, metal studs, and other physical obstructions that would impede Wi-Fi signal strength.

 **NOTE:** If a mobile device is able to connect to the Leader Wall Connector Wi-Fi, it is a good indication that the Follower Wall Connector will also be able to connect.

Calculating Power Sharing Requirements for Existing Systems

To calculate power supply requirements per number of Wall Connectors for existing electrical systems, use the following equation:

Available continuous amperage:	Number of Wall Connectors:	Max amperage output per Wall Connector when 100% utilized:
_____	_____	_____
_____ ÷ _____ = _____		

 **NOTE:** Maximum number of Wall Connectors for power sharing is 6.

 **NOTE:** When calculating maximum amperage per Wall Connector, 100% utilization must be greater than 6 amps for power sharing operation. If maximum amperage is greater than 48 amps, power sharing is not necessary.

For large scale sites, consider expected parking time in relation to a 100% utilization rate.

Expected Park Time (hours)	Examples	Recommended Amperage per wall Connector at 100% Utilization
6+ (long term)	Long term parking, overnight parking	12+ amps
3-5 (medium term)	Workplace, hospitality	24+ amps
1-2 (short term)	Shopping and dining	32+ amps

 **NOTE:** 100% utilization represents the worst case scenario for charging speeds, where the least amount of power would be available for each individual vehicle. In most situations, not all Wall Connectors would be actively charging a vehicle, which enables faster charging for the remaining vehicles.

Setting Up Power Sharing

Power sharing is a firmware feature that allows up to six Gen 3 Wall Connectors to limit their total grid current draw to a specified maximum current. This enables more connector installations and higher charging throughput by allowing individual Wall Connectors to be installed at their full current branch circuit capability, while setting a total allocated current so that the electrical service is not overloaded.



Firmware

Wall Connector firmware version **21.18.0 or higher** is required for Power Sharing operation. Connecting a Wall Connector to local Wi-Fi will allow for automatic firmware updates.

Terms

Table 3.

Power sharing network	A set number of Gen 3 Wall Connectors commissioned for wireless communication. A power sharing network shall consist of one Leader and multiple Follower Wall Connectors.
Leader	Refers to the Wall Connector unit that is set up as the sole controller of current allocation in a power sharing network. Acts as the primary controller of Follower Wall Connectors.
Follower	A Wall Connector under the control of a Leader.
Network Limit	The maximum total current a power sharing network is allowed to consume in amps.
Network Current	The sum total current of all Wall Connectors set up in a sharing network, in amps.
Network Size	The total number of Wall Connectors configured in a power sharing network.
Fallback (Fair) Limit	The maximum safe fallback current for a unit if communication is lost. Equal to (network limit) / (network size) bounded to within a single unit's capability.
Pilot Current	The current limit advertised to a connected vehicle by a single Wall Connector in amps.
Vehicle Current	The actual measured current consumption of a vehicle connected to a Wall Connector in amps.
Branch Circuit	The circuit conductors between the final overcurrent device protecting the circuit and the Wall Connector.
Shared Panel	A load center with multiple Wall Connector branch circuits, in addition to other unrelated electrical loads.
Dedicated EV Panel	A load center which is fully dedicated to Tesla Wall Connectors installed for power sharing.

Installation Options

Electric vehicle branch circuits can be installed in shared panels or dedicated EV panels.



Table 4.

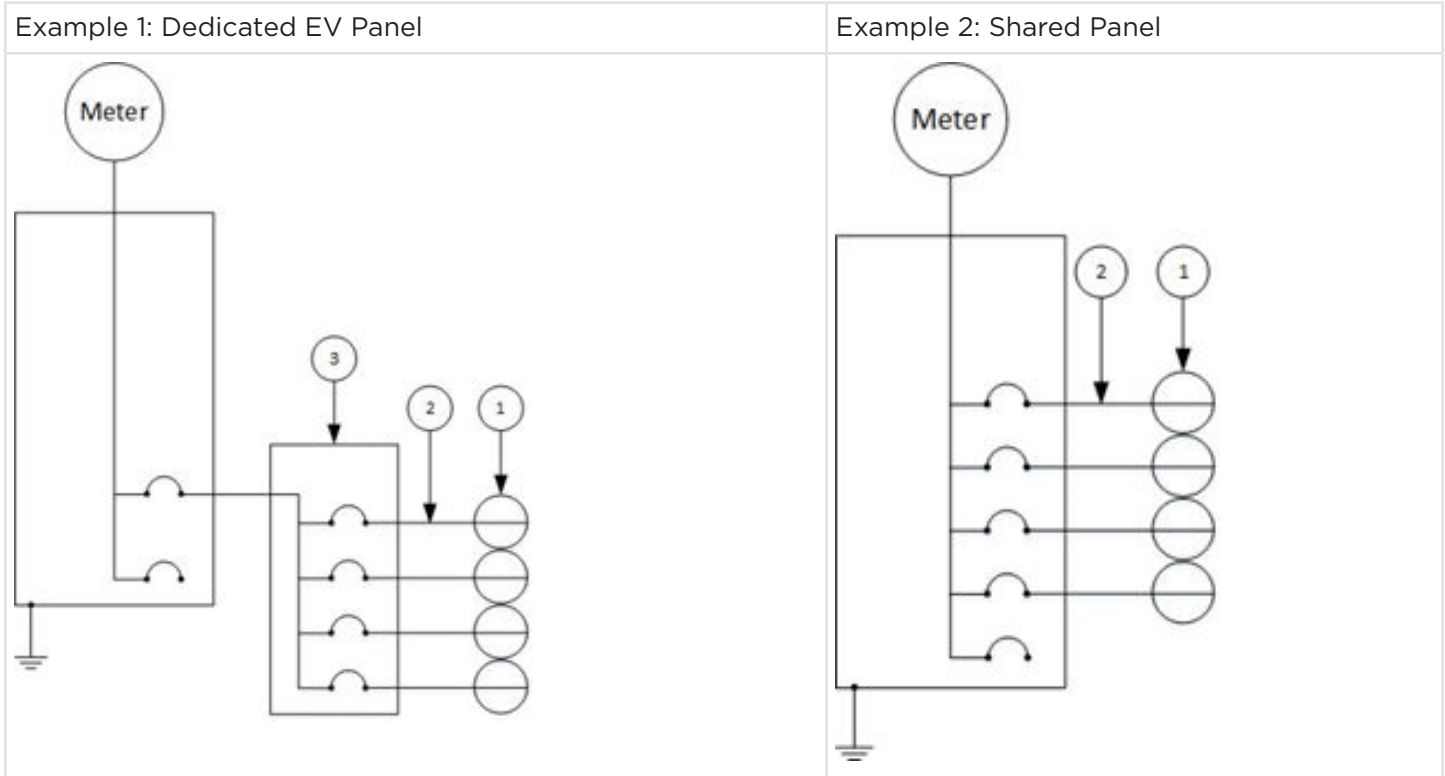

Setup Instructions - Order of Operations

1. Confirm each Wall Connector has firmware version 21.18.0 or higher to enable power sharing. In the Wall Connector Commissioning wizard, this can be found under the 'Software' card.



NOTE: When connecting to multiple wall connector, disable the auto-join network feature to ensure that your device does not re-join a Wall Connector you are no longer working on.

2. Once firmware version is confirmed, in the 'Installation' card of the commissioning wizard, set the country and power level for each Wall Connector. It is recommended to install each at the max circuit capacity; however, the branch circuit can be set to a lower output.
3. Designate a leader Wall Connector and add its follower units - see next page for more details.
4. Tap the 'Enabled' button on the leaders power sharing configuration page.
5. Connect the leader Wall Connector to the local Wi-Fi network, the leader in a power sharing network will share the Wi-Fi credentials with the follower units.

Power Sharing Commissioning

To begin, connect to the Commissioning Wizard for one of the Wall Connectors. This Wall Connector will become the "leader" unit and will be responsible for communicating available amperage to the network.

Select "Power Sharing" from the Commissioning Wizard:



1. Select "Add Wall Connector" to begin pairing process:

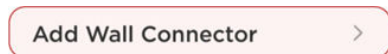



POWER SHARING

2. Follow on screen instructions to add a second Wall Connector by either scanning QR code from Quick Start Guide or manually entering the SSID and WPA2 info:

Note: the Wall Connector must be connected to the same WiFi network as this one.

SCAN QR CODE

To connect another Wall Connector, take a picture of the QR code sticker on the Quickstart Guide or QR code on the back of the enclosure. Make sure the QR code is in focus and sufficiently large in the photo for best results.

ENTER MANUALLY

To manually connect another Wall Connector, record the Wi-Fi network name and Password provided on the Quickstart Guide or on the back of the enclosure.

Table 5.

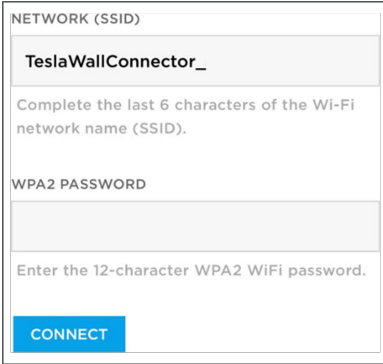
SCAN QR CODE	ENTER MANUALLY
<p>Locate Quick Start guide of the Wall Connector you want to add to the network</p> 	<p>Input SSID and WPA2 info from the Wall Connector you want to add to the network</p> 

 **NOTE:** The Wall Connector you are *adding* must be broadcasting its Wi-Fi SSID signal. Press and hold the

3. Repeat process to add more Wall Connectors to the network. All added Wall Connectors become followers in the network.
4. Select “Power Sharing Settings” to program a network limit.

Power Sharing Settings >

No network current limit set.
Configure a limit to enable power sharing.

5. In the field, input the network limit:



POWER SHARING

MAX NETWORK CURRENT (A)
<input type="text"/>
Enter the total current available for the power sharing network. A minimum of 6A per Wall Connector is required.

6.



NOTE: This is the maximum total current a power sharing network is allowed to consume in amps. This represents the continuous current which the network will not exceed. An electrician will need to determine the correct amount of amperage and confirm that the load center has appropriate overcurrent protection

Expected Behaviors

- SSID access point of all Wall Connectors in a power sharing network will continue to broadcast.
- Removing a Wall Connector from a network will temporarily set that device's max output to 6 amps. Cycle circuit breaker to reset Wall Connector to original configuration setting.
- Leader Wall Connector will share site Wi-Fi with follower Wall Connectors.

How to View Existing Power Sharing Networks

Table 6.

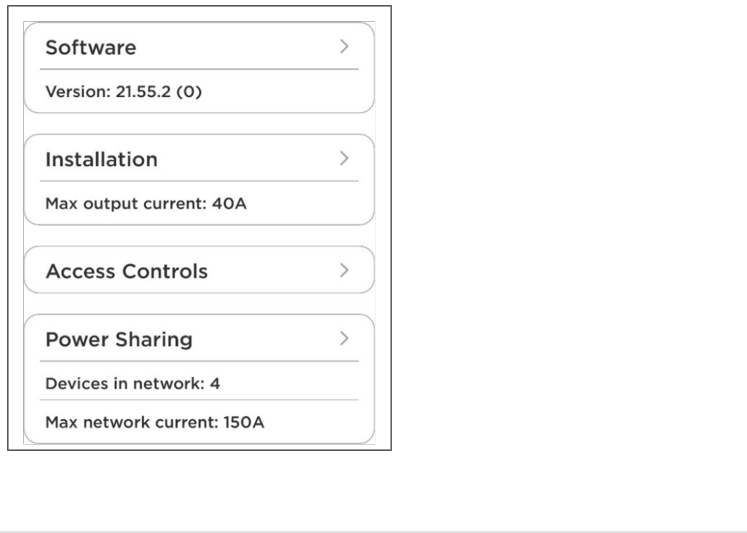
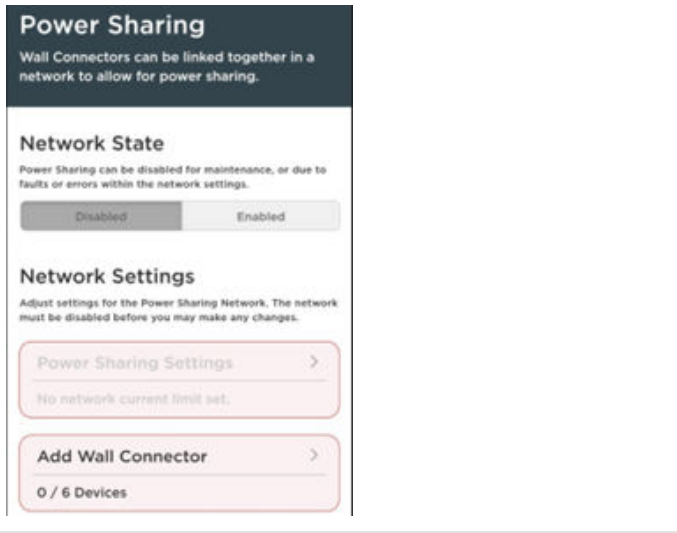
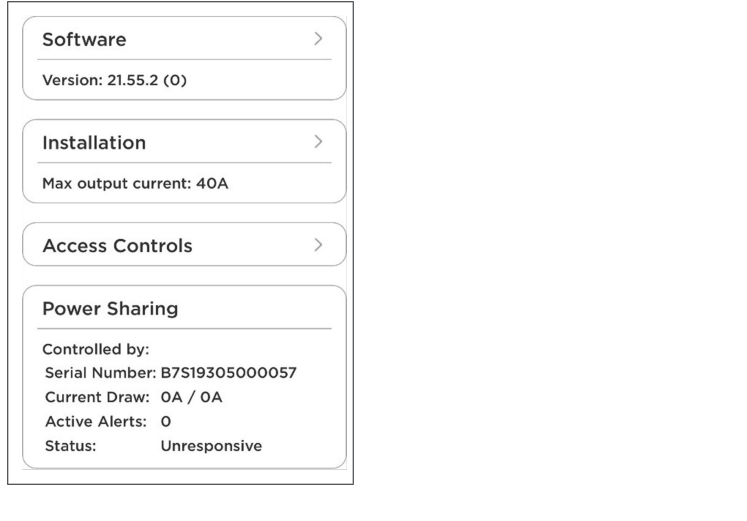
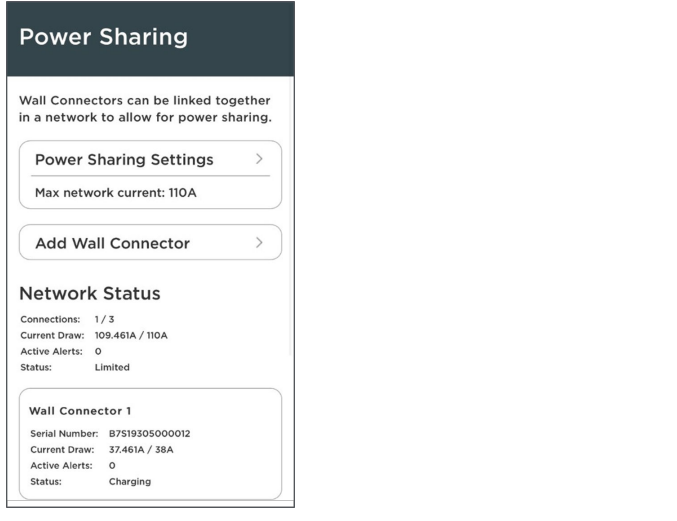
Leader Home Page	Leader Settings Page
 <p>The Leader Home Page displays four main menu items, each with a right-pointing chevron:</p> <ul style="list-style-type: none"> Software: Version: 21.55.2 (0) Installation: Max output current: 40A Access Controls Power Sharing: Devices in network: 4, Max network current: 150A 	 <p>The Leader Settings Page features a dark header for 'Power Sharing' with the text: 'Wall Connectors can be linked together in a network to allow for power sharing.'</p> <p>Network State: Power Sharing can be disabled for maintenance, or due to faults or errors within the network settings. A toggle switch is shown in the 'Enabled' position.</p> <p>Network Settings: Adjust settings for the Power Sharing Network. The network must be disabled before you may make any changes.</p> <p>Buttons include 'Power Sharing Settings' (with a chevron), 'Add Wall Connector' (with a chevron), and '0 / 6 Devices'.</p>
Follower Home Page	Follower Settings Page
 <p>The Follower Home Page displays four main menu items, each with a right-pointing chevron:</p> <ul style="list-style-type: none"> Software: Version: 21.55.2 (0) Installation: Max output current: 40A Access Controls Power Sharing: Controlled by: Serial Number: B7S19305000057, Current Draw: 0A / 0A, Active Alerts: 0, Status: Unresponsive 	 <p>The Follower Settings Page features a dark header for 'Power Sharing' with the text: 'Wall Connectors can be linked together in a network to allow for power sharing.'</p> <p>Buttons include 'Power Sharing Settings' (with a chevron) showing 'Max network current: 110A' and 'Add Wall Connector' (with a chevron).</p> <p>Network Status: Connections: 1 / 3, Current Draw: 109.461A / 110A, Active Alerts: 0, Status: Limited.</p> <p>Wall Connector 1: Serial Number: B7S19305000012, Current Draw: 37.461A / 38A, Active Alerts: 0, Status: Charging.</p>



REGISTERING THE WALL CONNECTOR IN THE TESLA APP - VEHICLE OWNERS

The Wall Connector can be registered in the Tesla App for an enhanced user experience including product warranty registration, charging history, and troubleshooting.

1. Open the Tesla app for iOS or Android.
2. Tap the account icon in the top left corner of the screen.
3. Tap **Add / Remove Products**.
4. Tap **Wall Connector** under the 'add' list.
5. Follow prompts to schedule charging and connect your Wall Connector to your home Wi-Fi network.



WALL CONNECTOR LEDS

Light Codes

Startup

Once energized at the circuit breaker, every LED (seven total) on the faceplate will illuminate for up to five seconds.



After Startup

After Wall Connector is energized at the circuit breaker, certain green LEDs (depending on the circuit breaker size) will illuminate for 10 seconds. See table below for exact light codes.

Circuit breaker	60 A	50 A	40 A	30 A	20 A	15 A
Maximum output	48 A	40 A	32 A	24 A	16 A	12 A

 **NOTE:** To re-display the green LEDs after the initial 10 seconds, press and hold the charging handle button.

When multiple Wall Connectors are linked for power sharing, the **center blue LED** will illuminate during the 10-second startup window.

Other

Standby, waiting to plug in	Charging in progress	SSID broadcasting, ready to commission	Waiting to charge, communicating with vehicle
Top green solid	Every green streaming	Green pulsing	Blue solid



Fault Codes

All red blink codes pause for one second, and then repeat.		
Light Bar	What It Means	Details
No Lights	Power supply issue, charging disabled	Verify that the power supply is turned on. If the issue persists, have an electrician remove the Wall Connector from the wirebox and confirm that voltage is present at the terminal block using a multimeter. Record the voltage readings for the following: L1 to L2/N, L1 to Ground, L2/N to Ground.
Solid red	Internal fault, charging disabled	Turn the circuit breaker off, wait 5 seconds, and turn it back on. If solid red light remains, document part number and serial number, then contact Tesla Energy.
One (1) red blink	Ground fault circuit interruption due to unsafe current path, charging disabled	Inspect the handle, cable, Wall Connector, and vehicle charge port for damage or signs of water ingress. Have an electrician check that ground is not directly connected to a conductor wire in the branch circuit.
Two (2) red blinks	Ground assurance fault, high ground resistance detected, charging disabled	Verify that the Wall Connector is properly grounded. The ground connection must be bonded in the upstream power supply for proper operation. Check all physical connections, including the wirebox terminals, electrical panel(s), and junction boxes. In residential power supplies, check the bond between ground and neutral at the main panel. If connected to a step-down transformer, contact the transformer's manufacturer for direction on how to bond the ground connection.
Three (3) red blinks	High temperature detected; charging limited or disabled	Verify that Wall Connector is connected to Wi-Fi and updated with the latest available firmware for optimal temperature sensing functionality. Check the faceplate and cable handle for excessive warmth. Have an electrician remove the Wall Connector from the wirebox and verify that the conductors used are sized correctly and that the terminal block is torqued to specification. Connect Wall Connector to Wi-Fi so that firmware can update to most recent version. If firmware does not automatically update, use the Commissioning Procedure on page 28 to sign into the commissioning wizard and manually update the firmware. If it does not solve the problem, contact our Customer Support team.
Six (6) red blinks	Overvoltage or poor grid quality detected, charging disabled	Verify that the power supply is nominal 200-240 volts. If the issue persists, have an electrician remove the Wall Connector from the wirebox and confirm that voltage readings are as expected at the terminal block using a multimeter. Record the voltage readings for the following: L1 to L2/N, L1 to Ground, L2/N to Ground.
Seven (7) red blinks	Vehicle overcurrent detected	Reduce the vehicle's charge current setting. If the issue persists and the attached vehicle is manufactured by Tesla, record the vehicle's VIN and approximate time of the fault and contact Tesla. If the vehicle is not manufactured by Tesla, contact the vehicle's manufacturer.



TORQUE SPECIFICATIONS

Table 7. Torque Specifications

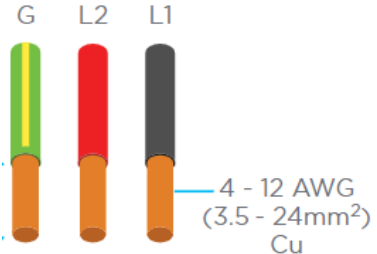
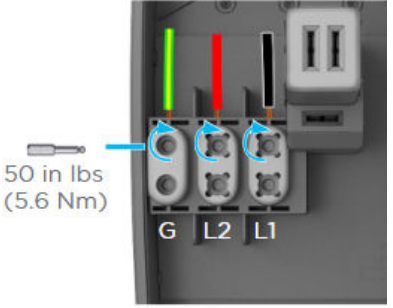
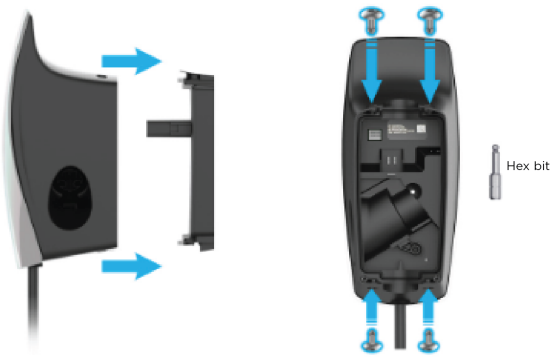
	Component	Specification
Electrical Terminations	 <p>G L2 L1</p> <p>4 - 12 AWG (3.5 - 24mm²) Cu</p>	strip to 13 mm
Terminal Connections	 <p>50 in lbs (5.6 Nm)</p> <p>G L2 L1</p>	5.6 Nm (50 in lbs)
M4 screws (x4)	 <p>Hex bit</p>	N/A



WARRANTY INFORMATION

Subject to the exclusions and limitations described below, the Charging Equipment Limited Warranty covers the refund, repair or replacement necessary to remedy any manufacturing defects in a Tesla manufactured and supplied Wall Connector that occur under normal personal use for a period of 48 months, or a period of 12 months for normal commercial use*, and a Tesla manufactured and supplied Mobile Connector or charging adapter that occur under normal use for a period of 12 months, starting from the date of invoice to the customer for any charging equipment. Any Tesla manufactured and supplied connector or adapter included in the initial purchase and delivery of a Tesla vehicle by Tesla is covered under the Basic Vehicle Limited Warranty section of the New Vehicle Limited Warranty for 4 years or 50,000 miles (80,000 km), whichever comes first, subject to the terms and conditions of the New Vehicle Limited Warranty.

*For warranty claims specific to Wall Connectors, “commercial use” means Wall Connectors used for purposes other than charging at a residential single family home a residential single family home a residential home or workplace for daily personal use, which includes, but is not limited to, charging at hotels, offices, parking lots and complexes (including apartment, condominiums and other multi-family or unit dwellings), and retail and other locations that allow (including by being listed online or publicly) for pay-for-use charging, or are located where users other than the owner could reasonably obtain access to the Wall Connector.

This Charging Equipment Limited Warranty does not cover any damage or malfunction directly or indirectly caused by, due to, or resulting from, normal wear or deterioration, abuse, misuse, negligence, accident, lack of or improper installation, use, maintenance, storage or transport, including, but not limited to, any of the following:

Failure to follow the instructions, operation, maintenance and warnings published in the documentation supplied with your Tesla connector or adapter;

External factors, including but not limited to, objects striking the Tesla connector or adapter, faulty or damaged electrical wiring or connections, external electrical faults, junction boxes, circuit breakers, receptacles or power outlets, the environment or an act of God, including, but not limited to, fire, earthquake, water, lightning and other environmental conditions;

General appearance or damage to paint, including chips, scratches, dents and cracks;

Failure to contact Tesla upon discovery of a defect covered by this Charging Equipment Limited Warranty;

Any repair, alteration or modification to the Tesla connector or adapter or any part, or the installation or use of any parts or accessories, made by a person or facility not authorized or certified to do so; and

Lack of or improper installation, repair or maintenance, including use of non-genuine Tesla accessories or parts.

Although Tesla does not require you to perform all maintenance, service or repairs at a Tesla Service Center or Tesla authorized repair facility, this Charging Equipment Limited Warranty may be voided, or coverage may be excluded, due to lack of or improper maintenance, service or repairs. Tesla Service Centers and Tesla authorized repair facilities have special training, expertise, tools and supplies with respect to Tesla connectors and adapters and, in certain cases, may employ the only persons, or be the only facilities authorized or certified to work on Tesla connectors and adapters. Tesla strongly recommends that you have all maintenance, service and repairs done at a Tesla Service Center or Tesla authorized repair facility in order to avoid voiding, or having coverage excluded under, this Charging Equipment Limited Warranty.



Limits of Liability

This Charging Equipment Limited Warranty is the only express warranty made in connection with your Tesla connector or adapter. Implied and express warranties and conditions arising under applicable local laws, federal statute or otherwise, in law or in equity, if any, including, but not limited to, local laws, federal statute or otherwise, in law or in equity, if any, including, but not limited to, Korean Law, except for causes caused by Tesla's intention or gross negligence, implied warranties and conditions of merchantability or merchantable quality, fitness for a particular purpose, durability, or those arising by a course of dealing or usage of trade, or any warranties against latent or hidden defects, are disclaimed to the fullest extent allowable by your local law, or limited in duration to the term of this Charging Equipment Limited Warranty. To the fullest extent allowable by your local law, the performance of necessary repairs and/or replacement of new, reconditioned, or remanufactured parts by Tesla for the covered defects is the exclusive remedy under this Charging Equipment Limited Warranty or any implied warranties. To the maximum extent permissible under your local law, liability is limited to the reasonable price for repair or replacement of the applicable Tesla connector or adapter, not to exceed the manufacturer's suggested retail price except for cases caused by Tesla's intention or gross negligence. Replacement may be made with parts of like kind and quality, including non-original manufacturer's parts, or reconditioned or remanufactured parts, as necessary. This Charging Equipment Limited Warranty covers only parts and factory labor necessary to repair but does not include any on-site labor costs related to un-installing, reinstalling or removing the repaired or replacement charging equipment. Parts repaired or replaced, including replacement of a Tesla connector or adapter, under this Charging Equipment Limited Warranty are covered only until the applicable warranty period of this Charging Equipment Limited Warranty ends, or as otherwise provided by applicable law. Under no circumstances will the original warranty period be extended as a result of your Tesla connector or adapter being repaired or replaced.

Except for cases caused by Tesla's intention or gross negligence, Tesla shall not be liable for any defects under this Charging Equipment Limited Warranty that exceed the fair market value of the applicable Tesla connector or adapter at the time immediately preceding the discovery of the defect. In addition, the sum of all benefits payable under this Charging Equipment Limited Warranty shall not exceed the price you paid for the applicable Tesla connector or adapter.

Tesla does not authorize any person or entity to create for it any other obligations or liability in connection with this Charging Equipment Limited Warranty. Subject to local laws and regulations, the decision of whether to repair or replace a part or to use a new, reconditioned or remanufactured part will be made by Tesla, in its sole discretion. Tesla may occasionally offer to pay some or all of the cost of certain repairs that are not covered by this Charging Equipment Limited Warranty, either for specific models or on an ad hoc, case-by-case basis. Tesla reserves the right to do the above at any time without incurring any obligation to make a similar payment to other Tesla charging equipment owners.

To the maximum extent permissible under local law, Except for cases caused by Tesla's intention or gross negligence, Tesla hereby disclaims any and all indirect, incidental, special and consequential damages arising out of, or relating to, the Tesla connector or adapter, including, but not limited to, transportation to and from a Tesla Authorized Service Center, loss of the Tesla connector or adapter, loss of vehicle value, loss of time, loss of income, loss of use, loss of personal or commercial property, inconvenience or aggravation, emotional distress or harm, commercial loss (including but not limited to lost profits or earnings), towing charges, bus fares, vehicle rental, service call charges, gasoline expenses, lodging expenses, damage to tow vehicle, and incidental charges such as telephone calls, facsimile transmissions, and mailing expenses.

The above limitations and exclusions shall apply whether your claim/warranty claim is in contract, tort (including negligence and gross negligence), breach of warranty or condition, misrepresentation (whether negligent or otherwise), or otherwise at law or in equity, even if Tesla is advised of the possibility of such damages or such damages are reasonably foreseeable.



WARRANTY INFORMATION

Nothing in this Charging Equipment Limited Warranty shall exclude, or in any way limit, Tesla's liability for death or personal injury solely and directly caused by Tesla's negligence, or that of its employees, agents or sub-contractors (as applicable), fraud or fraudulent misrepresentation, or any other liability to the extent the same is proven in a court of competent jurisdiction in a final nonappealable judgment and may not be excluded or limited as a matter of local law.

Dispute Resolution

To the fullest extent allowed by local law, Tesla requires that you first provide written notification of any manufacturing defect within a reasonable time, and within the applicable coverage period specified in this Charging Equipment Limited Warranty, and allow Tesla an opportunity to make any needed repairs before submitting a dispute to our dispute settlement program (described below). Please send written notification on dispute resolution to the following address:

Vehicles registered in the China:

Tesla Motors (Beijing) Co., Ltd.
8F, Tower 3 China Central Place
No.77 Jianguo Road
Chaoyang District, Beijing
Phone: 86 400 910 0707

Vehicles registered in the U.S.:

Tesla, Inc
3500 Deer Creek Road
Palo Alto, California
Attention: Charging Equipment Warranty Claims
Phone number: 1-877-79-TESLA (1-877-798-3752)

Vehicles registered in the Korea:

Tesla Korea Ltd.
Address: Seoul, Gangnam 730
Recipient: Charging warranty
Phone number: 080-617-1399

Vehicles registered in the Japan:

Tesla Motors Japan GK 2-23-8
Minami Aoyama, Minato-ku, Tokyo Gaien Building 1st floor
Phone number: 03-4570-4270



WARRANTY INFORMATION

Vehicles registered in the Hong Kong, Macau:

Tesla Motors HK Limited

Units 01-08, 11/F, KITEC, 1 Trademart Drive

Kowloon Bay, Kowloon, Hong Kong

Phone: +852 3974 0288

Vehicles registered in the Australia:

Tesla Motors Australia, Pty Ltd

ACN 142 889 816

Level 14, 15 Blue Street

North Sydney NSW 2060, Australia

Phone: 1800 646 952

Vehicles registered in the New Zealand:

Tesla New Zealand ULC

c/o Quigg Partners

Level 7, The Bayleys Building,

36 Brandon Street,

Wellington 6011, New Zealand

Phone: 0800 005 431

Vehicles registered in Europe, Middle East:

Burgemeester Stramanweg 122

1101EN Amsterdam, Netherlands

Charging Equipment Limited Warranty

Vehicles registered in the UK:

Tesla Motors Ltd

Company number: 04384008

197 Horton Road, West Drayton

England, UB7 8JD

Vehicles registered in Taiwan:

在台灣登記的車輛:



WARRANTY INFORMATION

台灣特斯拉汽車有限公司

台北市內湖區民權東路六段 11 巷 6 號

收件人: Charging Equipment Warranty Claims

電話號碼: 886-2-66103880

Vehicles registered in South Africa:

Tesla Motors Ltd

Company number: 04384008

197 Horton Road, West Drayton

England, UB7 8JD

Vehicles registered in Israel:

Tesla Motors Israel Ltd

Company number: 516106986

Amal 70, Petah Tikva, 4951370

Israel

Please include the following information:

- Tesla connector or adapter invoice date
- Tesla Part Number and Serial Number
- Your name and contact information
- Name and location of the Tesla Store and/or Tesla Service Center nearest to you
- Description of the defect
- History of the attempts you have made with Tesla to resolve the concern, or of any repairs or services that were not performed by Tesla
- In the event any disputes, differences, or controversies arise between you and Tesla related to this Charging Equipment Limited Warranty, Tesla will explore all possibilities for an amicable settlement
- Even though with all the effort, in the event the dispute between Tesla and the customer cannot be resolved as described above, legal disputes arising out of this warranty shall be determined by a competent court in accordance with the Civil Procedure Act and the decision of the court

Agreement to Arbitrate

Please carefully read this provision, which applies to any dispute between you and Tesla, Inc. and its affiliates (together “Tesla”).

If you have a concern or dispute, please send a written notice describing it and your desired resolution to resolutions@tesla.com.



WARRANTY INFORMATION

If not resolved within 60 days, you agree that any dispute arising out of or relating to any aspect of the relationship between you and Tesla will not be decided by a judge or jury but instead by a single arbitrator in an arbitration administered by the American Arbitration Association (AAA) under its Consumer Arbitration Rules. This includes claims arising before this Charging Equipment Limited Warranty, such as claims related to statements about our products.

Tesla will pay all AAA fees for any arbitration, which will be held in the city or county of your residence. To learn more about the Rules and how to begin an arbitration, you may call any AAA office or go to www.adr.org.

The arbitrator may only resolve disputes between you and Tesla and may not consolidate claims without the consent of all parties. The arbitrator cannot hear class or representative claims or requests for relief on behalf of others purchasing or leasing Tesla products. In other words, you and Tesla may bring claims against the other only in your or its individual capacity and not as a plaintiff or class member in any class or representative action. If a court or arbitrator decides that any part of this agreement to arbitrate cannot be enforced as to a particular claim for relief or remedy (such as injunctive or declaratory relief), then that claim or remedy (and only that claim or remedy) shall be severed and must be brought in court and any other claims must be arbitrated.

If you prefer, you may instead take an individual dispute to small claims court.

You may opt out of arbitration within 30 days after signing this Charging Equipment Limited Warranty by sending a letter to: Tesla, Inc.; P.O. Box 15430; Fremont, CA 94539-7970, stating your name, product, and intent to opt out of the arbitration provision. If you do not opt out, this agreement to arbitrate overrides any different arbitration agreement between us, including any arbitration agreement in a lease or finance contract.



CALL US TO ORDER TODAY!
585.533.4051
500 Canal View Blvd • Suite 100
Rochester, NY 14623

TESLA

Revision 1.0